



2021/04



# INSTALLATION MANUAL

Double Glass Modules

## Jetion Solar (China) Co., Ltd.

Add: 1011 Zhencheng Road, Jiangyin, Jiangsu Province, P.R. China 214443

Tel: +86 (510) 8668 7300

E-mail: [marketing@jetion.com.cn](mailto:marketing@jetion.com.cn)

Web: [www.jetionsolar.com](http://www.jetionsolar.com)

JX-PI-RD-003 A1

Please read this manual carefully before installation and keep it for future reference.

INTRODUCTION.....	1
DISCLAIMER OF LIABILITY.....	1
<b>1、CERTIFICATES REQUIREMENTS.....</b>	<b>1</b>
1.1 IEC 61215 & 61730.....	1
1.2 UL.....	1
<b>2、INSTALLATION REQUIREMENTS.....</b>	<b>1</b>
2.1 Installation environment requirements.....	1
2.2 Orientation and tilt for modules installation.....	2
2.3 Materials requirements.....	2
2.4 The requirements for different types of mounting.....	3
<b>3、MOUNTING METHODS.....</b>	<b>4</b>
3.1 For single-sided double glass modules.....	4
3.2 For Bifacial double glass modules.....	4
3.3 Clamping mounting.....	4
<b>4、GROUNDING.....</b>	<b>5</b>
<b>5、WIRING.....</b>	<b>6</b>
5.1 For the wiring, pay attention to:.....	6
5.2 The number of modules in series and in parallel in a system.....	7
5.3 PID effect prevention.....	7
5.4 Clean and protection of connectors.....	7
<b>6、LOADING &amp; UNLOADING AND TRANSPORTATION.....</b>	<b>8</b>
6.1 Module Loading & Unloading.....	8
6.2 Storage.....	8
6.3 Unpack.....	8
6.4 Module carrying.....	8
6.5 Others.....	9
<b>7、MAINTENANCE AND CLEANING.....</b>	<b>9</b>
<b>8、CHECKLISTS.....</b>	<b>9</b>
<b>9、WARNING!.....</b>	<b>9</b>
<b>10、HAZARD WARNINGS:.....</b>	<b>10</b>
Appendix 1 : Applicable Products.....	11
Appendix 2:Electrical Specifications.....	12

E-mail: [marketing@jetion.com.cn](mailto:marketing@jetion.com.cn)

Web: [www.jetionsolar.com](http://www.jetionsolar.com)

## INTRODUCTION

- Jetion Solar photovoltaic modules consist of crystalline silicon solar cells, high transmission and low iron tempered glass, anti-aging EVA and high flame resistant back sheet, and anodized aluminum alloy frame.
- Jetion modules are qualified for international standard IEC61215 and IEC61730. Jetion modules can be used in ground PV stations, roof solar systems, communication stations and BIPV etc.
- We are committed to providing technical and installation support for our customers worldwide.
- This manual contains important information regarding the installation, safe handling and maintenance of PV modules made by Jetion.
- All instructions should be read and understood prior to installation. The installer should conform to all requirements in this manual. The appropriate local standards and regulations, construction rules and safety instructions should also be followed during installation. All related work on a PV system must be carried out only by appropriately qualified and certificated engineers, who must be familiar with international and local the mechanical and electrical standards and principles including cable connection, building codes, etc for such PV system.

## DISCLAIMER OF LIABILITY

- The installation, handling and use of Jetion modules are beyond company control. Therefore, Jetion assumes no responsibility for loss, damage, injury or expense resulting from improper installation, handling, use or maintenance.
- Jetion reserves the right to update the products, specifications or this INSTALLATION MANUAL without prior notice.

## 1、CERTIFICATES REQUIREMENTS

### 1.1 IEC 61215 & 61730

- Jetion modules are designed to meet the requirements of IEC 61215, IEC61730, and also fulfill the criteria of Application Class A. Modules that are rated as Application Class A may be used in systems operating with DC higher than 50V or 240W. Modules rated as Application Class A and qualified for security authentication of IEC61730 are considered to meet the requirements of safety class II.

### 1.2 UL

- The electrical characteristics are within +/- 3% of the rated values of  $I_{sc}$ ,  $V_{oc}$  and  $P_{mp}$  under standard test condition (irradiance of 100 mW/cm<sup>2</sup>, AM 1.5, and cell temperature of 25°C).
- The stand-off height should be at least 100mm (3.94in), and the recommended stand-off height is 115mm (4.53in). If other mounting means are employed, it may affect the Fire Class.
- The modules have been evaluated by UL for a maximum positive or negative design loading of 50 lb/ft<sup>2</sup>.
- Wiring methods should be in accordance with the NEC.
- For installation in Canada, the installation shall also be in accordance with CSA C22.1, safety Standards for Electrical Installations, Canadian Electrical Code, Part 1.

## 2、INSTALLATION REQUIREMENTS

### 2.1 Installation environment requirements

- **Avoid shading**
  - Even if the smallest local shelter (such as dust deposition) will also decrease the output power.
- **Adequate ventilation**

- High temperature of the module may reduce the performance and output power of the module. Good ventilation can effectively avoid the overheating of PV modules.

● **Others**

- Do not install the module near inflammable gas. (such as gas station, air tank etc.)
- Do not install the module near naked flame or flammable materials.
- Do not install the module in a location with potential extreme sand and dust damage.
- Do not install the module in a location with extreme air pollution, such as chemical vapors, acid rain, heavy metal particle fume, and/or soot.
- Do not expose the module close to a laser source.
- Do not install the module in a location with extreme hail and/or snow.
- Do not install the module in a location where it could be immersed in water or continually exposed to water from a sprinkler or fountain.
- Do not install the module in a marine environment and/or area where salty wind hit directly. It is recommended that the module should be installed at least 500m from the sea.
- The recommended environment temperature: -20°C to 40°C.
- Operating temperature: -40°C to 85°C.

**2.2 Orientation and tilt for modules installation**

- Solar modules produce the max power when they are pointed directly at the sun. In order to achieve maximum annual yield, optimum orientation and tilt of PV modules is necessary. The modules, which connected in a system, must be in the same orientation and tilt, otherwise, it will lose the power because of the differences of sunshine radiation.

- The modules must be facing the north in the south hemisphere, and facing south in the north hemisphere. For off-grid installations where the Jetion modules are attached to a permanently structure, the Jetion modules should be tilted for optimum winter performance. As a rule, if the system power production is adequate in winter, it will be satisfactory during the rest of the year. The maximum output tilt of the module is the angle between the solar module and the ground. At the same time, it shall be determined by the system designer according to the terrain, landform, wind power, wind speed, meteorological resources and system mechanical properties of the installation site.

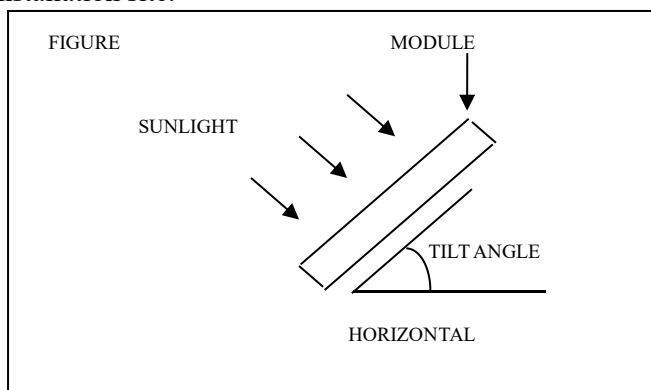

Fig. 1 Module Tilt Angle

RECOMMENDED TILT ANGLES FOR A FIXED SYSTEM	
SITE LATITUDE IN DEGREES	FIXED TILT ANGLE
0° TO 15°	15°
15° TO 25°	SAME AS LATITUDE
25° TO 30°	LATITUDE+5°
30° TO 35°	LATITUDE+10°
35° TO 40°	LATITUDE+15°
40° +	LATITUDE+20°

Table15 Module Tilt Angle

**2.3 Materials requirements**

● **Support structure**

- The support structure of the module shall be made of abrasion proof, corrosion resistant and UV resistant materials which correspond to the appropriate structural requirements. The mounting structure and the module attachments must be designed in accordance with the local wind and snow loads.

● **Bypass diode**

- Partial shading of an individual module can cause a reverse voltage across the shaded module. Current is then



forced go through the shaded area by the other unshaded modules. When a bypass diode is wired in parallel with the series string, the current of unshaded area will detoured round the shaded area and flow though the diode and bypass, thereby minimizing module heating and array current losses.

### ● **Blocking diode**

- In a system that uses a battery, blocking diodes are typically placed between the battery and the module output to prevent battery discharge at night and rainy weather.

- Diodes that are used as blocking diodes must have a:

- Rated Average Forward Current  $[I_{F(AV)}]$  above the maximum system current at the highest module operating temperature.

- Rated Repetitive Peak Reverse Voltage  $[V_{RRM}]$  above the maximum system voltage  $[V_{max}]$  at the lowest module operating temperature (IEC:  $V_{max}=1000V$  or  $1500V$ ).

### ● **Battery**

- When solar modules are used to charge batteries, the battery must be installed in a manner which will protect the performance of the system and the safety of its users. The battery should be away from the mainstream of people and animal crowds. Select a battery site that is protected from sunlight, rain, snow, debris, and is well ventilated. Most batteries generate hydrogen gas when charging, which is explosive. Do not light matches or create sparks near the battery bank. When a battery is installed outdoors, it should be placed in an insulated and ventilated battery case specifically designed for the purpose.

### ● **Cable and other components**

- Ensure that all components meet the requirements of the systems` maximum voltage, current, humidity, and temperature when they are exposed to sunlight. We recommended that all wiring and electrical connections comply with the appropriate national electrical and building code.

- Under normal condition,a photovoltaic module is likely to experience conditions that produce higher current and/or voltage than reported at standard test conditions.Accordingly,the values of  $I_{sc}$  and  $V_{oc}$  marked on this module should be multiplied by a factor of 1.25 when determining component voltage ratings,conductor current ratings,fuse sizes,and size of controls connected to the PV output.Refer to section 690-8 of the U.S. National Electric Code for an additional multiplying of 1.25 which may be applicable.

- Only cables with one conductor are to be used.

- The area of the cable mated with the connector is recommended to be  $4\sim 6\text{ mm}^2$ , length: 1000mm, temperature range: $-40^{\circ}\text{C}$  to  $90^{\circ}\text{C}$ . IMax.Series fuse (Mono-156&Poly-156: IMax.Series fuse=15A; Mono-166: IMax.Series fuse=20A; Mono-182: IMax.Series fuse=25A).

## 2.4 The requirements for different types of mounting

The modules can afford 2400Pa wind load and 5400Pa snow load. Which can also afford 25mm diameter hail impact at 82km/h.

### ● **Ground mounting**

- Select the height of the mounting system to prevent the lowest edge of the module from being covered by snow for a long time in winter in areas that experience heavy snowfalls.In addition,assure the lowest portion of the module is placed high enough so that it is not shaded by grass, and sand and stone driven by wind.

### ● **Roof mounting**

- When installing a module on a roof or building,ensure that it is securely fastened and cannot fall as a result of wind or snow load.

- The modules are supported parallel to surface of the building wall or roof. Clearance between the module frames and surface of the wall or roof is required to prevent wiring damage and to allow air to circulate behind the module.The stand-off height should be at least 100mm (3.94in).The recommended stand-off height is 115mm (4.53in).

- The modules must be installed onto a Classified Roofing system. The amount of area the modules cover may degrade the roof's original fire rating in some locations. Do not install modules on a roof or building during strong

winds in case of accident.

● **Pole mounting**

· When installing a module on a pole, choose a pole and module mounting structure that should withstand anticipated winds for the area.

**3、MOUNTING METHODS**

**3.1 For single-sided double glass modules**

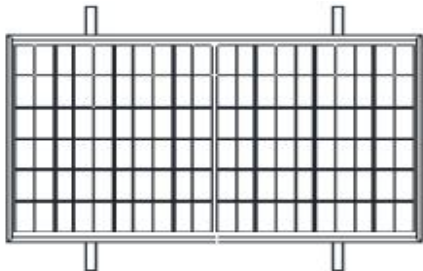
Module	Mechanical Load	Safety Factor	Mounting Direction
Single-sided double glass modules	+3600Pa/-1600Pa	1.5 (noted: Suitable for both 60pcs and 72 pcs modules)	

**3.2 For Bifacial double glass modules**

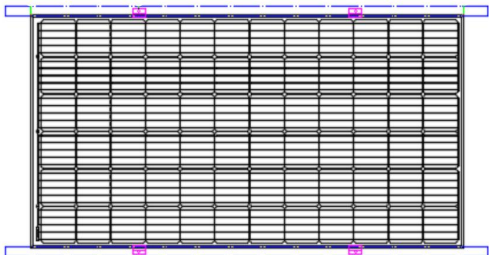
Module	Mechanical Load	Safety Factor	Mounting Direction
Bifacial double glass modules	+3600Pa/-1600Pa	1.5 (noted: Suitable for both 60pcs and 72 pcs modules)	

**3.3 Clamping mounting**

The clamps must not overlap the glass or shade the module surface, or distort the frame. Recommended torque is 5Nm.

➤ **Standard Mounting**

Clamp installation (the movement range of the mounting rail)

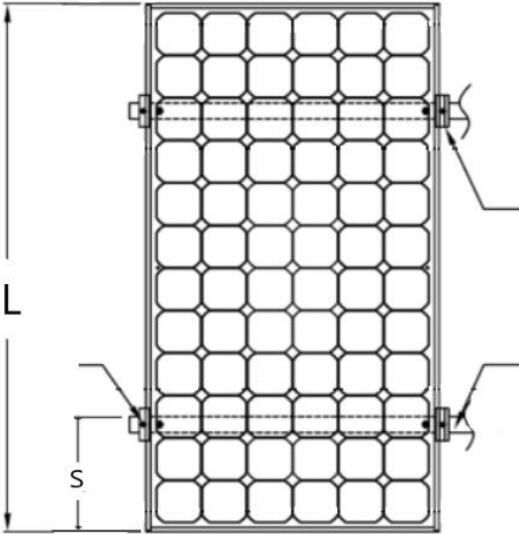

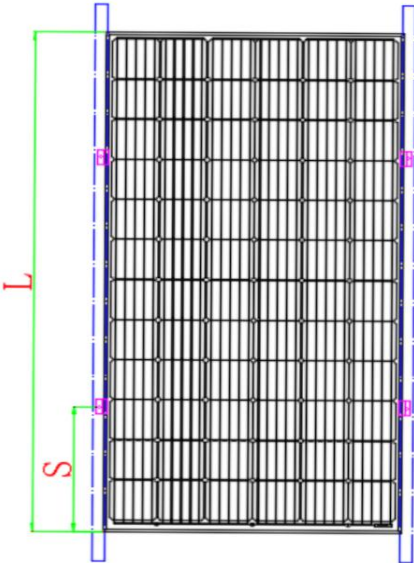

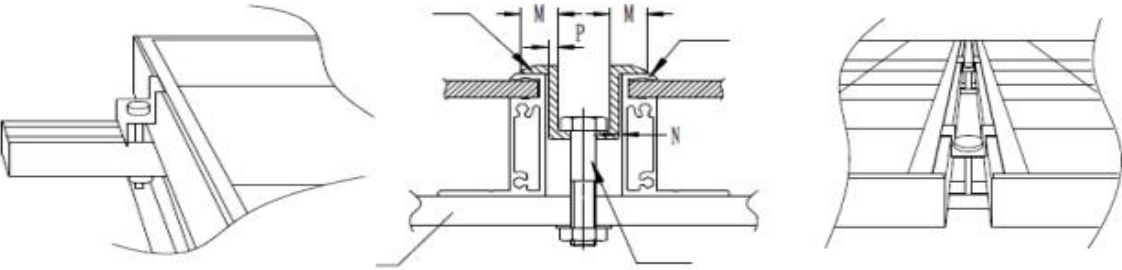
Single-sided double glass modules	Bifacial double glass modules
<p>1.Mounting range: <math>(1/4L-50) \cong S \cong (1/4L+50)</math> (L is the length of Module)</p> <p>2.3600Pa (positive ) &amp;1600Pa (negative)</p> <p>3.Mechanical load, the satey factor is 1.5</p> <p>4.Applied torque should refer to mechanical design standard according to the bolt customer is using, ex: M8 ---- 16-20N.m(140-180lb.in)</p> <p>5.The size of the module can reference in Appendix 1</p>	
<p>End clamp 2pcs/module(both ends) &amp; Middle clamp 2pcs/module(modules in the middle)</p>	
	

## 4、GROUNDING

- To avoid the risk of electrical shock or fire,the module frame should be grounded before the electrical connection of the modules is operated.
- The frame shall be grounded in accordance with NEC Article 250 (USA) or CEC in Canada.
- For an adequate grounding,the grounding hardware should penetrate the anodic oxidation layer.
- Jetion recommends using the following components or equivalents.

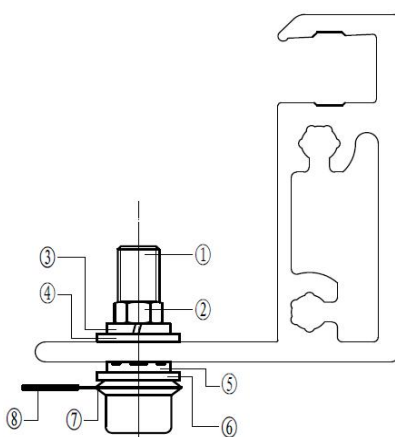

- ① Stainless steel bolt
- ② Stainless steel nut
- ③ Stainless steel spring washer
- ④ ⑥ Stainless steel flat washer
- ⑤ Stainless steel lock-toothed washer
- ⑦ Stainless steel cup washer
- ⑧ Grounding wire

Fig. 6

- Attach a separate conductor as grounding wire to the 4mm diameter grounding holes with a set of M4 bolt, cup washer, flat washer, lock-toothed washer, spring washer, and nut.
- Jetion's photovoltaic module can be grounded by using the third-party earthing device, which is applicable to the metal frame earthing of the photovoltaic module and shall be installed according to the manufacturer's INSTALLATION MANUAL.
- Exposed copper of the grounding wire shall not contact the module frame in case of corroding the frame.

## 5、 WIRING

### 5.1 For the wiring, pay attention to:

- Correct wiring scheme: To minimize the risk of indirect lightning strike, avoid forming closed loops when designing the system. Check that wiring is correct before operating the photovoltaic system. If the measured open circuit voltage ( $V_{oc}$ ) and short-circuit current ( $I_{sc}$ ) are different from those in the specifications, there may be a wiring fault.
- The J-Box Jetion uses on the backside of the module is weatherproof and is designed to be used with standard wiring or conduit connections. Wiring methods should be in accordance to the NEC (National Electrical Code). Bypass diodes and cable clamps are included with each module when the modules are shipped out from the factory.
- Use modules of the same specification in the same system. When connected in series, all modules must have the same current. When connected in parallel, the modules must all have the same voltage. The quantity of modules to be connected should match the voltage specifications of the devices used in the system. The modules must not be connected together to create a voltage, which is higher than the permitted system voltage. When designing the system, please always take into consideration the variation of the voltage under different temperatures (please check the respective temperature coefficients of the modules, the  $V_{oc}$  of the modules will be rise when the temperature drops). The current and voltage data on module label are typical data. As for its actual tested data, please refer to the flash report.
- Make sure the connector is clean and the sealing ring is complete before connection. The male and female connectors shall connect tightly, and poor connection may cause the junction electrical leakage and burning at the junction. The shell of Junction box and the connector are of organic materials, so they cannot contact with organic solvents, otherwise They will get deformed or cracked.

The minimum bending radius of the module cable is not less than four times of the cable diameter.



Wrong bending mode

Correct bending mode

- When the cable is fixed on the support, never damage the cable or module mechanically. Never press the cable with force. The special light-fast bundle and line card shall be used for fixing the cable properly on the support. Although the cable can resist sunshine and water, avoid direct sunshine and water as much as possible.

### 5.2 The number of modules in series and in parallel in a system

- When modules are connected in series, the total voltage should be less than the maximum system voltage  $V_{max}$  (IEC:  $V_{max}=1000V$  or  $1500V$ ).



- When modules are connected in parallel, the total current should be less than the maximum system current.
- The modules shall be connected in a serial manner followed by the parallel way. If a reverse current exist, which exceeds the largest fuse current, an over-current protection device of equal specification shall be used to protect the modules. If there are two or more parallels of modules, one over-current protection device and one anti-reverse charging diode shall be installed on each parallel.

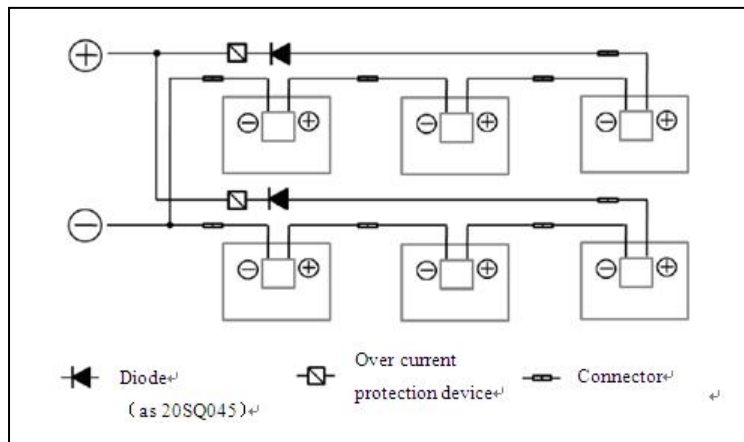

### 5.3 PID effect prevention

- It is recommended to adopt negatively earthed installation of inverter to avoid the PID effect for non-anti PID modules.
- It is recommended to adopt negatively earthed installation of inverter to avoid the PID effect for water PV projects.
- If the inverter does not have negatively earthed function, PID restorer (PID-box) can also be adopted.

### 5.4 Clean and protection of connectors

- During module installation, connectors are easily exposed in air, and even contact with the land, which causes pollution to connectors. It is not allowed to use organic solvents to clean connectors (eg. electrode cleaner), because it will easily cause a crack on the connector.
- The connector is easily corroded in the environment where there are the chemical substances below. Please never save it in the environment with chemical substances marked by “△” in long term and never make it contact the chemical substances marked by “×”.

No.	Type of chemical substances	Endurance capacity	NO.	Type of chemical substances	Endurance capacity
1	Aliphatic hydrocarbon	×/△	8	Ether	×
2	Aromatic hydrocarbon	×	9	Inorganic acid	×/△
3	Halogenated hydrocarbon	×	10	Organic acid	△
4	Ethyl alcohol	+	11	Oxidizing acid	×
5	Phenol	×	12	Alkaline	×
6	Ketone	×	13	Gasoline	×
7	Ester	×/△	Note: +,good ; △,Moderate; ×,Poor		

## 6、LOADING & UNLOADING AND TRANSPORTATION

### 6.1 Module Loading & Unloading

- If the modules are to be transported by containers, the fork tooth of electric forklift shall go from the pallet's

short edge when lifting the pallets. The fork tooth's length must be longer than two-thirds of the pallets length, if fork tooth's length can not meet the requirement, a tooth sleeve shall be added to lengthen the fork tooth. If the modules are to be transported by platform cars, fork tooth can go from the pallet's long edge, but slotting space must be adjusted to the biggest, and go in the middle of the gap at the long edge. Forklift truck shall maintain a constant speed, forbid a sudden acceleration or stop, lift and drop slowly to avoid module concussion.

## 6.2 Storage

- Store the arrived modules properly to avoid breakage. Jetion modules are packed vertically, and each pallet is vertically placed with two boxes; Please separate the top box and bottom box once the modules arrived.
- For temporary storage, please store the modules in dry and well ventilated space, with temperature 0 - 40 °C, humidity: 30% -70%.
- The current grade labels of different colors are attached to the outer box and the frame. The same system shall be installed with modules of same current grade .

## 6.3 Unpack

- Correct unpack method:  
First, tear off packing belts and wrapping Film, and open the top cover.;  
Second, two constructors lift modules vertically from the package in turn, and take out modules. The remaining modules in the box shall be inclined to the other side.

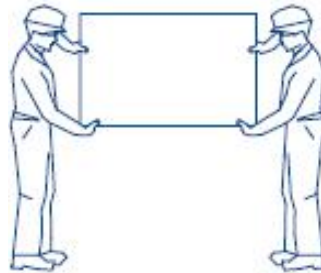

Correct way to take out the module

## 6.4 Module carrying

- The module should be carried by two people with both hands whether it's to be moved or lifted. It's not allowed for a single person or a single hand to carry the module. It's forbidden to lift the module by grasping the junction box or cable.

## 6.5 Others

- Before the modules arriving the site, please don't unpack the box, and please protect the package from damage.
- Smoothly loading and unloading the modules, don't place on a slope or seriously uneven ground to avoid the package slanting or falling. When stacking modules, do not exceed the allowed max layers printed on the package.

## 7、 MAINTENANCE AND CLEANING

- Do not change the PV components optionally (diode, junction box, plug connectors ).
- Given a sufficient tilt (at least 15°), it is not generally necessary to clean the modules (rainfall will have a

self-cleaning effect). In case of heavy dust adhesion (which will result in output reductions), we recommend cleaning the modules with plenty of water and using a gentle cleaning tool (for example, a sponge).

- Dirt must never be scraped or rubbed away when it's dry, as this will cause micro-scratches. We recommend that the system be inspected at regular intervals.
- Do not clean the modules with cold water during the warmer hours of the day in order to avoid creating any thermal shock that may damage the module.
- **CAUTION : DON'T USE DETERGENTS CONSISTING OF ABRASIVE, ACETONE OR OTHER CORROSIVE ELEMENTS.**

## 8、CHECKLISTS

- All fastenings are tight, secure and free of corrosion.
- All cable connections are secure, tight, clean and free of corrosion.
- All connectors are not damaged in any way.
- Checking the earthen resistivity of metals.

## 9、WARNING!

- The maximum load on the module must not exceed 30 lb/ft<sup>2</sup> ( 146.5 kg/m<sup>2</sup> ). To avoid exceeding the maximum load, real-time load for specific areas such as wind and snow should be taken into account.

When modules or strings are planned to be connected in parallel, a fuse should be used in each string. The number of modules in series is based on the maximum system voltage of the module used, and the corresponding combiner box, inverter are matched.

- The open-circuit voltage of all modules in series should never exceed the max system voltage.
- The plug connector has its own polarity. Make sure that the connection is safe and tight. Ensure that they are in good electrical and mechanical condition.
- The plug connector should not receive extreme stress.
- Never pull the connector and cable forcefully and the well bound cable can be untied by special tools (such as pliers).
- Never rotate the fixed nut of the connector.
- Do not attempt to drill holes in the surface glass of the modules.
- Do not drill additional mounting holes in the frame of the modules.
- Do not hoist the module by the J-Box or cable.
- Never use a module with broken glass or torn substrate. Broken modules cannot be repaired and contact with any module surface or frame can lead to electrical shock.
- Do not install or handle modules when they are wet or during the period of high wind.
- Keep children well away from the system while transporting and installing mechanical and electrical components.
- Do not strike or physically damage the module.
- Avoid cutting and damaging the frame, the front side or the backside surface of the module during handling and installation.
- Do not stand or step on the module.
- Do not put extra objects on the module lest the glass will be broken.
- The J-Box must be on the higher side of the module when it is mounted.

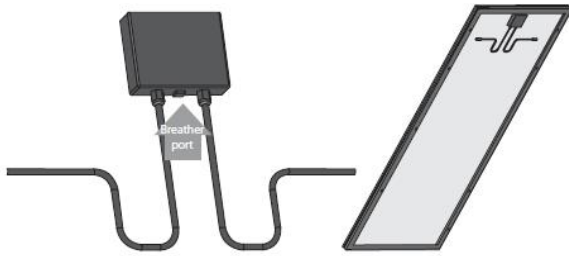

- Do not dismantle or drop the module, and do not remove any attached nameplate or components from the module.
- Do not bend or twist the module.
- Do not apply paint or adhesive to module top surface.
- Do not use pointed or sharp objects with the module.
- Artificially concentrated sunlight shall not be directed on the module.
- Precipitation can run off through small openings on the back side of the module. Make sure that the openings are not masked after mounting.
- Do not wear rings, watch, and metal jewelry during installation.

## 10、HAZARD WARNINGS:



### **Danger of death from electric shock!**

PV modules generate electricity as soon as they are exposed to sunlight. One module generates a safe, extra low voltage level, but multiple modules connected in series (summing the voltage) or in parallel (summing the current) represent a danger. The following points must be noted when handling the solar modules to avoid the risk of fire, sparking and fatal electric shock.

- **Do not insert electrically conducting parts into the plugs or sockets!**
- **Do not fit solar modules and wiring with wet plugs and sockets!**
- **Exercise utmost caution when carrying out work on wiring and safety equipment (use insulated tools, insulated gloves, etc.)!**
- **Do not use damaged modules! Do not dismantle modules! Do not mark on the rear of the module using sharp objects!**
- **Exercise utmost caution when working on wiring and the inverter. Be sure carefully to follow manufacture's installation instructions!**



### **Danger of death from arcing!**

- **Modules generate direct current when light shines on them. An electric arc may be generated when connectors are used to turn the circuit on or off. Don't touch the connectors. When breaking a connected string of modules (e.g. when disconnecting the line from the inverter under load), a lethally strong arc can occur.**
- **Since the modules have been connected into working system, there would be electric arc while being switched off, so the operation should be finished by certificated, professional electrician.**
- **Ensure the connectors are clean and have not been contaminated, and that the electrical connection and mechanical joint are good!**

## Appendix 1 : Applicable Products

N o.	Cell/p cs	Cell Type	Module model	Size(L×W×T=Length× Width×Thickness) /mm	Mounting holes	Note
1	60	mono	JT305SXh	1658×992×6	Frameless	
2	72	mono	JT365STh	1968×992×6	Frameless	
3	120	mono	JTxxxSlh	1716 × 1005 x 40/25/30	990-1300 400-990-1300	xxx=300~325 , xxx,in step of 5
4	120	mono	JTxxxSlh	1789×1048×25/30 1773×1046×30	990-1300 400-990-1300	xxx=355~370 , xxx,in step of 5
5	144	mono	JTxxxSSh	2043× 1005 x 40/25/30	990-1300 400-990-1300	xxx=360~390 , xxx,in step of 5
6	144	mono	JTxxxSSh	2132×1048×25/30 2111×1046×30	990-1300 400-990-1300	xxx=430~445 , xxx,in step of 5
7	60	mono	JTxxxSXh(B)	1664 x 998 x 40/25/30 1686 x 1004 x 40/25/30	990-1300 400-990-1300	xxx=295~330 , xxx,in step of 5
8	72	mono	JTxxxSTh(B)	1977×998×40/25/30 2009 x 1004 x 40/25/30	990-1300 400-990-1300	xxx=350~395 , xxx,in step of 5
9	120	mono	JTxxxSlh(B)	1789×1048×25/30 1773×1046×30 1755×1038×30 1908×1134*30/35	990-1300 400-990-1300	xxx=355~380 , xxx,in step of 5 xxx=430~460 , xxx,in step of 5
10	144	mono	JTxxxSSh(B)	2132×1048×25/30 2111×1046×30 2094×1038×30 2256×1133*35 2279×1134*35	990-1300 400-990-1300 400-990-1400	xxx=430~455 , xxx,in step of 5 xxx=520~555 , xxx,in step of 5
11	108	mono	JTxxxSJh(B)	1724×1134*30/35	400-990-1300	xxx=385~415,



						xxx,in step of 5
12	132	mono	JTxxxSLh(B)	2073×1133*30/35 2094×1134*30/35	400-990-1300	xxx=475~505, xxx,in step of 5

## Appendix 2:Electrical Specifications

No.	Module Type	Maximum Power at STC (Pmax, Wp)	Open-circuit voltage, (Voc,V)	Short-circuit current, (Isc,A)	Voltage at max. power, (Vmp,V)	Current at max.power, (Imp, A)
1	JT360SSh	360	48	9.58	39.2	9.19
2	JT365SSh	365	48.2	9.66	39.4	9.27
3	JT370SSh	370	48.4	9.74	39.6	9.35
4	JT375SSh	375	48.6	9.82	39.8	9.43
5	JT380SSh	380	48.8	9.9	40	9.51
6	JT385SSh	385	49.0	9.97	40.2	9.58
7	JT390SSh	390	49.3	10.03	40.5	9.64
8	JT430SSh	430	49.2	11.16	40.6	10.6
9	JT435SSh	435	49.4	11.23	40.8	10.67
10	JT440SSh	440	49.6	11.3	41	10.74
11	JT445SSh	445	49.8	11.37	41.2	10.81
12	JT430SSh(B)	430	49.2	11.16	40.6	10.6
13	JT435SSh(B)	435	49.4	11.23	40.8	10.67
14	JT440SSh(B)	440	49.6	11.30	41	10.74
15	JT445SSh(B)	445	49.8	11.37	41.2	10.81
16	JT450SSh(B)	450	50.0	11.44	41.4	10.87
17	<b>JT455SSh(B)</b>	<b>455</b>	<b>50.2</b>	<b>11.51</b>	<b>41.6</b>	<b>10.94</b>
18	JT300SIh	300	39.2	9.85	32.4	9.26
19	JT305SIh	305	39.4	9.93	32.7	9.33
20	JT310SIh	310	39.6	10.03	32.9	9.43
21	JT315SIh	315	39.9	10.1	33.1	9.52
22	JT320SIh	320	40.2	10.16	33.4	9.59
23	JT325SIh	325	40.5	10.2	33.7	9.65
24	JT355SIh	355	40.7	11.14	33.7	10.54
25	JT360SIh	360	40.9	11.23	33.9	10.62
26	JT365SIh	365	41.1	11.32	34.1	10.71
27	JT370SIh	370	41.3	11.41	34.3	10.79
28	JT355SIh(B)	355	40.7	11.14	33.7	10.54
29	JT360SIh(B)	360	40.9	11.23	33.9	10.62
30	JT365SIh(B)	365	41.1	11.32	34.1	10.71
31	JT370SIh(B)	370	41.3	11.41	34.3	10.79
32	JT375SIh(B)	375	41.5	11.49	34.5	10.87
33	JT380SIh(B)	380	41.7	11.58	34.7	10.96
34	JT350STh(B)	350	47.51	9.43	39	8.98
35	JT355STh(B)	355	47.68	9.53	39.2	9.06
36	JT360STh(B)	360	47.85	9.63	39.4	9.14
37	JT365STh(B)	365	48.02	9.71	39.7	9.2

38	JT370STh(B)	370	48.19	9.82	40	9.25
39	JT375STh(B)	375	48.28	9.85	40.2	9.33
40	JT380STh(B)	380	48.37	9.89	40.5	9.39
41	JT385STh(B)	385	48.46	9.92	40.2	9.58
42	JT390STh(B)	390	48.55	9.96	40.5	9.64
43	JT395STh(B)	395	48.65	9.99	40.7	9.71
44	JT295SXh(B)	295	38.9	9.77	32.1	9.19
45	JT300SXh(B)	300	39.1	9.87	32.3	9.3
46	JT305SXh(B)	305	39.4	9.93	32.7	9.33
47	JT310SXh(B)	310	39.6	10.03	32.9	9.43
48	JT315SXh(B)	315	39.9	10.1	33.1	9.52
49	JT320SXh(B)	320	40.2	10.16	33.4	9.59
50	JT325SXh(B)	325	40.5	10.2	33.7	9.65
51	JT330SXh(B)	330	40.8	10.26	34	9.71
52	JT430SIh(B)	430	40.5	13.58	33.8	12.73
53	JT435SIh(B)	435	40.7	13.65	34.0	12.80
54	JT440SIh(B)	440	40.9	13.72	34.2	12.87
55	JT445SIh(B)	445	41.1	13.79	34.4	12.94
56	JT450SIh(B)	450	41.3	13.86	34.6	13.01
57	JT455SIh(B)	455	41.5	13.93	34.8	13.08
58	JT460SIh(B)	460	41.7	14.00	35.0	13.15
59	JT520SSh(B)	520	48.8	13.57	40.9	12.72
60	JT525SSh(B)	525	49.0	13.63	41.1	12.78
61	JT530SSh(B)	530	49.2	13.69	41.3	12.84
62	JT535SSh(B)	535	49.4	13.75	41.5	12.90
63	JT540SSh(B)	540	49.6	13.80	41.7	12.95
64	JT545SSh(B)	545	49.8	13.86	41.9	13.01
65	JT550SSh(B)	550	50.0	13.92	42.1	13.07
66	JT555SSh(B)	555	50.2	13.98	42.3	13.13
67	JT385SJh(B)	385	36.4	13.56	30.3	12.71
68	JT390SJh(B)	390	36.6	13.64	30.5	12.79
69	JT395SJh(B)	395	36.8	13.72	30.7	12.87
70	JT400SJh(B)	400	34.0	13.80	30.9	12.95
71	JT405SJh(B)	405	34.2	13.88	31.1	13.03
72	JT410SJh(B)	410	34.4	13.95	31.3	13.10
73	JT415SJh(B)	415	34.6	14.03	31.5	13.18
74	JT475SLh(B)	475	44.6	13.58	37.4	12.71
75	JT480SLh(B)	480	44.8	13.64	37.6	12.77
76	JT485SLh(B)	485	45.0	13.71	37.8	12.84
77	JT490SLh(B)	490	45.2	13.77	38.0	12.90
78	JT495SLh(B)	495	45.4	13.83	38.2	12.96
79	JT500SLh(B)	500	45.6	13.90	38.4	13.03
80	JT505SLh(B)	505	45.8	13.96	38.6	13.09